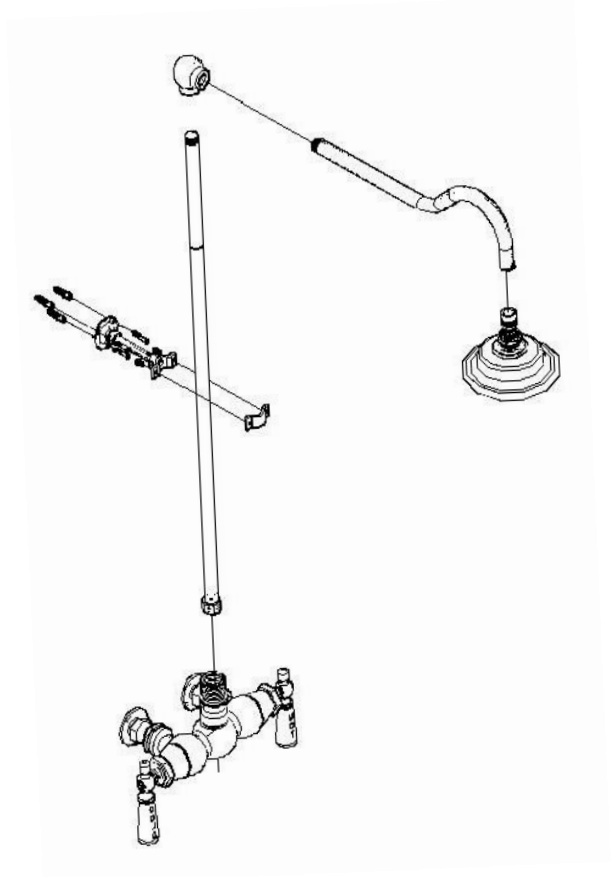
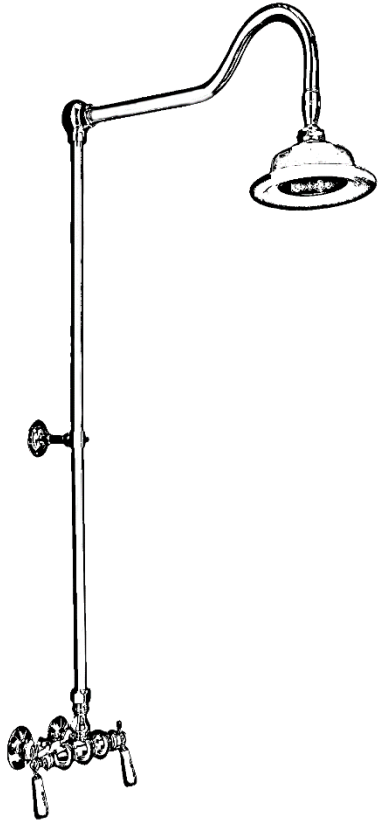

Exposed Shower System Wall Mounted Set**GUARANTEE & AFTERCARE**

When installing or using tools, take care to avoid damaging the finish or fitting. Clean regularly with a soft damp cloth only to maintain appearance; avoid abrasive cleaners or detergents as they may cause surface damage. The company guarantees against faulty materials or manufacturing, excluding serviceable parts, if installed, cared for, and used according to our instructions.

WATER SUPPLY REGULATIONS

This product has been manufactured to comply with the relevant standards and conform to Water Supply Regulations.

COMPONENTS LIST

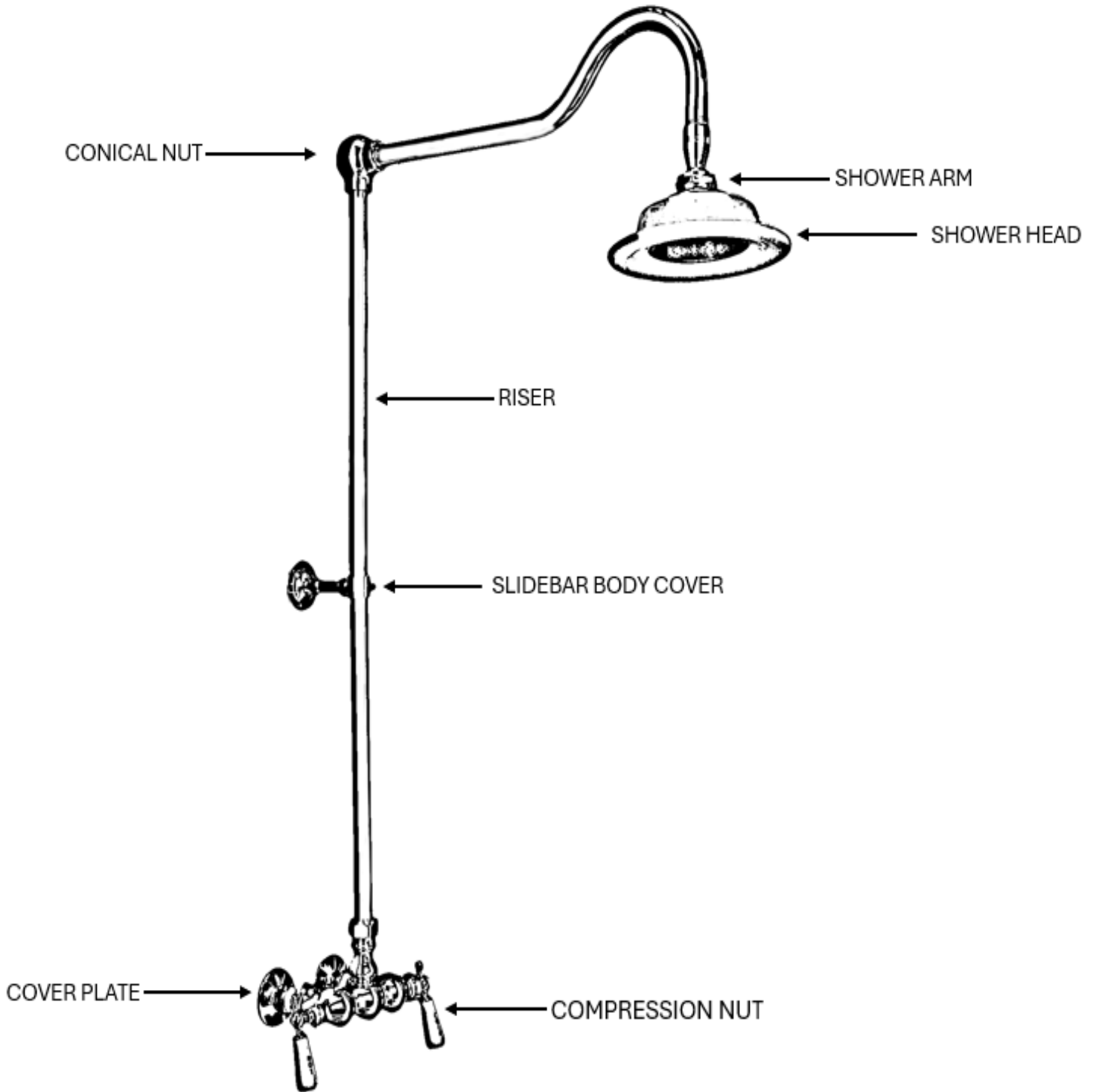

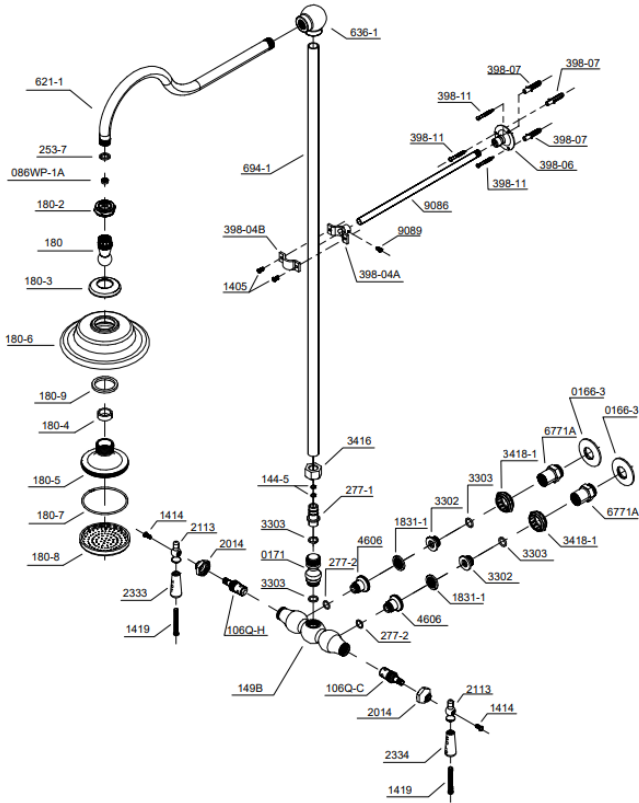

BILL OF MATERIAL				
ITEM	PT/ASSY	DESCRIPTION	TYPE	QTY
1	180-6	Shower Head	ASSEMBLY	1
2	3416	Locknut	ASSEMBLY	1
3	2014	Escutcheon	ASSEMBLY	2
4	1414	Screw	ASSEMBLY	2
5	086WP-1A	Brass Ferule	ASSEMBLY	1
6	694-1	Riser Pipe	ASSEMBLY	1
7	149B	Faucet Body	ASSEMBLY	1
8	398-06	Wall Mount Bracket	ASSEMBLY	1
9	180-2	Rubber Flat Washer	ASSEMBLY	1
10	398-04B	POM Clip	ASSEMBLY	1
11	2113	Handle-Hot	ASSEMBLY	2
12	0166-3	Wall Flange	ASSEMBLY	2
13	6771A	Comp nut	ASSEMBLY	2
14	3418-1	Brass Ferule	ASSEMBLY	2

